



WH-SF40 AND WH-SF60

Whole House **SimplySoft®** **Water Softener**

40,000 Grains & 60,000 Grains
Owner's Manual





Experience the luxury of soft water. Your new Aquasana SimplySoft® Water Softener was expertly engineered to reduce hard water minerals, ensuring soft, scale-free water throughout your home.

Our SimplySoft® softeners help you save up to \$497 annually* by improving appliance efficiency, reducing repairs, and cutting soap costs. Protect your pipes and appliances, get spotless dishes and shower doors, prevent wear and fading in your clothing and linens, and enjoy soft water that's gentle on skin and hair — all by reducing hard water in your home.

WH-SF40 AND WH-SF60

Whole House SimplySoft® Water Softener

TABLE OF CONTENTS

Box Contents & System Configuration.....	1-2
Precautions/Safeguards.....	3
Installation Steps.....	4-12
System Maintenance	13-16
Troubleshooting Guide	17
Product Specifications & Performance	18
Warranty	19
Water for Life® Program.....	20

*Potential savings based on Water Quality Research Foundation Battelle Institution Study.

If you have added components to your Whole House SimplySoft® Water Softener, note the correct sequencing below.

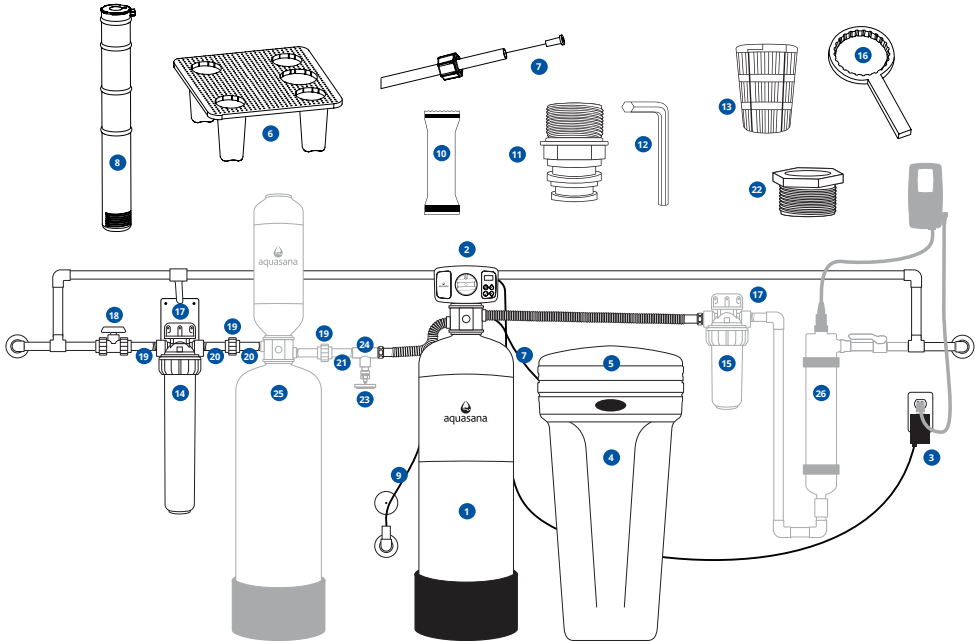

The following components may vary based on the purchased configuration.

- | | |
|--------------------------------------|---------------------------------|
| 1 SimplySoft® Pressure Tank | 14 Pre-Filter |
| 2 Control Valve | 15 Post-Filter |
| 3 Transformer | 16 Plastic Wrench |
| 4 Brine Tank | 17 Filter Support Brackets |
| 5 Brine Tank Lid | 18 Shut-Off Valve |
| 6 Grid Plate & Feet (4) | 19 Slip Unions |
| 7 Brine Tubing & Insert | 20 2.5" TOE Nipples |
| 8 Safety Shut-Off Assembly | 21 3" Smooth Nipple |
| 9 Drain Line & Clamp | 22 1"-3/4" Reducer Bushings (2) |
| 10 Grease Packet | 23 Brass Drain Valve |
| 11 1" Straight Threaded Fittings (2) | 24 PVC Tee |
| 12 Allen Wrench | 25 Rhino® Filter Tank |
| 13 Upper Basket | 26 UV Filter |

Box contents may be packaged in multiple boxes.

Before beginning installation, please ensure all parts listed are present. If any part is missing or damaged, do not attempt to install the system.

Before beginning installation, ensure you have a copy of your most recent water test results for your home's water hardness. This is required when setting the controller.

Not all configurations can be addressed in this Owner's Manual. Appearance and quantity of parts/components may vary depending on the time of purchase.

Please contact Customer Support for replacement parts at **866-662-6885**.

Tools recommended for installation:

- 80 lbs of water softener salt (2 bags)
- 2 adjustable wrenches
- Drill
- Channel locks
- Pipe cutter
- NSF certified PVC primer and glue
- NSF certified plumber's tape
- 5 gallon bucket

Optional components:

- Copper wire & grounding clamps (if copper pipes are present)
- Pex tubing, crimp rings, and cutter
- Garden hose

[>> Click here to view the SimplySoft® Water Softener installation video.](#)

- For all installations: Due to the varieties of home design, not all configurations can be addressed in this guide. Anticipate the need for additional parts and pieces including but not limited to pex tubing, clamps, and mounting screws to install unit properly (available at a local home improvement store or through your plumbing contractor).
- Installation of the system must comply with existing state and local plumbing and electrical codes.
- General plumbing knowledge is required for installation. Installation by a licensed plumber or certified installer is recommended.
- This system is not intended for treating water that is microbiologically unsafe or of unknown quality without adequate disinfection before or after the system.
- Do not install this softener where the line pressure may exceed 125 psi. The operating pressure range for this softener is between 30 psi – 125 psi. In areas with high pressure (over 80 psi), we recommend installing a pressure reducing valve ahead of the softener.
- Install on cold water lines only (40° - 110°F).
- It is recommended your system be installed indoors and out of direct sunlight. Prolonged exposure to light can weaken plastic components, resulting in housing failure. If this is not possible and the system is outdoors or in a sunny area, the unit must be protected from both direct sunlight and freezing temperatures.
- Unit must be installed in an area where the main water line enters your home, before connecting to the water heater. DO NOT install after a water heater or on the hot water line.
- DO NOT install the system on its side.
- Pick an appropriate installation location where if the system or any connection thereto should leak, the resulting flow of water will not cause damage to the surrounding area.
- NSF certified plumber's tape (thread sealing tape) is the only sealer that can be used on threaded fittings.
- Properly tighten all fittings to ensure a leak-free assembly.
- DO NOT use petroleum-based lubricant. Use only 100% silicone lubricant.
- DO NOT use pliers or pipe wrenches except when indicated. All plastic connections should be hand tightened only.

NOTE: Installation could take 1-4 hours to complete. Plan accordingly as you will be without water throughout the home during this time.

Precipitated minerals or sediment can cause damage to the seals and pistons. If precipitated minerals or sediment are present in your water supply this will be considered a harsh environment. The seals and pistons would not be covered by warranty, stated or otherwise.

1 Select Location

Consider the following when selecting where to install the system:

1. Outside taps used to water lawns and gardens should be isolated from the water line required to supply untreated water to the inlet of the water softener.
2. Location should be as close as possible to the water supply source.
3. Location should be as close as possible to an existing or pre-installed drain location, and a 120 volt AC electrical outlet.
4. Softener should be installed before the water heater.
5. Ensure the system sits level.
6. Allow sufficient space around the system for easy servicing.

NOTE: Check local plumbing codes requirements for use of check valve, back-flow prevention, or vacuum breaker.

2 Assemble Brine Tank

1. Attach the 4 brine legs to the grid plate. The legs will snap on to the tabs of the plate making a 'click' sound.

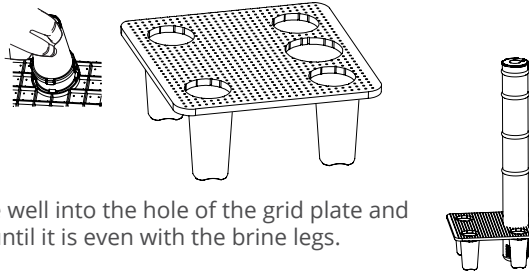

2. Insert the brine well into the hole of the grid plate and push through until it is even with the brine legs.
3. Place the brine grid with the brine well inside the brine tank so that the nut fitting faces the hole on the brine tank. The handle of the brine tank should also align with the brine well. Then, press the grid evenly inside the brine tank until the brine legs and the brine well touch the bottom of the tank.

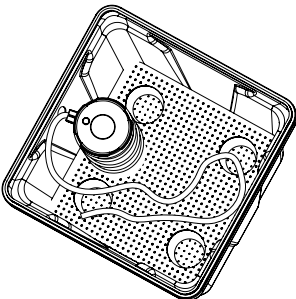

IMPORTANT: The hole in the brine tank should line up with the brine line as shown.

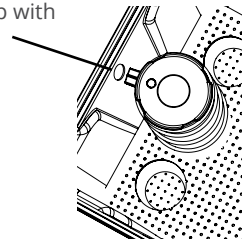

2 Assemble Brine Tank *(cont. from previous page)*

4. Ensure the attached tube stiffener is inserted into the brine tube. Then, take the brine tube and insert the nut and plastic sleeve as shown below. Insert the tube in the brine well elbow and hand-tighten the nut. Pull the opposite end of the brine tube through the hole on the brine tank to prepare for installation.

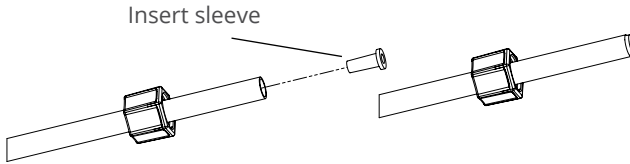

5. Keep brine tank lid to the side until instructed to add salt.

3 Prepare Pressure Tank

1. Apply the supplied lubricant to the internal o-ring at the bottom of the control valve. Apply lubricant to the larger o-ring on the bottom of the valve that seals with the tank threads.

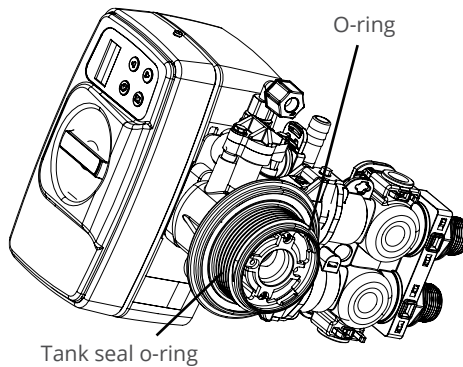

NOTE: Do not use petroleum-based lubricants as they will cause swelling of the o-ring seals.

2. Attach the upper basket to the control valve. Do so by lining up recesses on edge of upper basket with clips on the white retainer on the bottom of the control valve. Insert the basket and rotate to the right to lock into position.

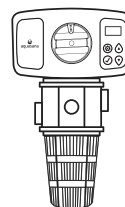
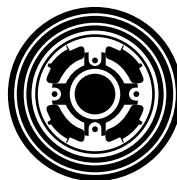
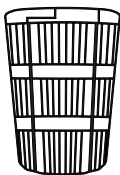

3 Prepare Pressure Tank *(cont. from previous page)*

- Remove the tape from the top of the riser tube. Carefully position the control valve and basket over the riser tube, inserting riser into the internal o-ring. Turn the control valve to the right into the threads of the tank until secure.

NOTE: Ensure the quick connect power cord is not yet connected to prevent the cord getting caught between the threads of the tank and the valve.

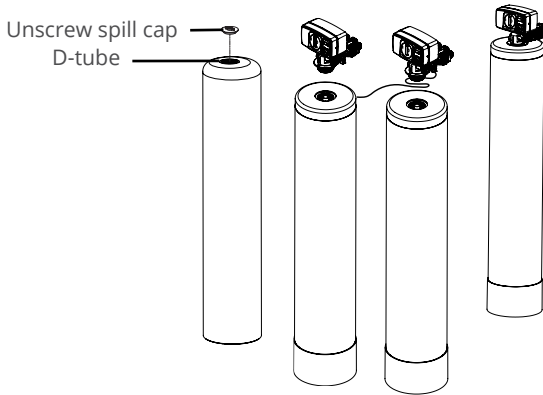

- Wrap plumber's tape around threaded ends of both fittings 3-4 times.
- Apply the supplied lubricant to the attached o-rings on both fittings.
- Connect both fittings to the bypass by removing the red clips, inserting the fittings and reattaching the red clips to hold in place.

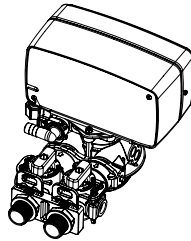

4 Ensure Spacing and Cut Pipes

NOTE: Pre-assemble all parts and dry-fit the entire system to ensure proper spacing and to confirm you have the necessary components for installation. Reference system configuration image on page 1 to under the system layout and connections.

If you have additional attachments and/or upgrades, please reference those manuals before final installation.

- Turn off the main water source. Drain water from lines to relieve pressure by turning on a faucet at the lowest elevation inside your home.

4 Ensure Spacing and Cut Pipes *(cont. from previous page)*

- Using a pipe cutter, cut into the main water supply line and catch any remaining water in the 5 gallon bucket.
- Measure distance for pre-filter and optional add-ons, and mark accordingly.

NOTE: DO NOT cut more pipe than necessary. You can cut more pipe later if needed.

- Cut pipe along the marked sections from previous step and clean ends of pipe. Ensure there are no burrs, sharp edges, or deep scratches.

NOTE: Cut tubing as straight as possible with a utility knife, or an appropriate pipe cutter for copper, PVC, or PEX tubing.

5 Configure System

System configuration may vary. Instructions provided are for base Aquasana install kit.

- Fit pre-filter, pressure tank, brine tank, and any optional add-ons into the system as this time.
- Attach the pre-filter to your incoming water line.
- Attach the filter wall bracket to the pre-filter housing with included screws. Once this is complete, screw the support bracket to the wall.

NOTE: Additional materials may be needed to ensure pre-filter brackets are supported and properly secured to the wall.

- Ensure all parts are flowing through the "IN" port in the correct direction of water flow.
- Connect the threaded nipple from the pre-filter outlet to the union attached to the pressure tank inlet.

NOTE: Verify connection to the correct side of the pressure tank connections indicated by the arrows on top of the valve. The INLET port is on the side with the drain and brine lines. DO NOT PLUMB BACKWARDS.

- Connect the threaded nipple from the pre-filter outlet to a union, and from the union to the pressure tank inlet.
- Once installation is complete, allow proper time for the glue to dry. During this time, ensure all connections are tight.

6 Connect the Drain Line

1. Attach the ½" drain hose to the drain line fitting with provided clamp. Tighten with screwdriver.
2. Run the drain line to the existing softener drain. Measure tubing and cut excess as needed.
3. Complete any necessary plumbing to maintain a proper air gap.

NOTE: The waste connections or drain outlet must be designed and constructed to provide for connection to the sanitary waste system through an air gap of 2 pipe diameters or 1", whichever is larger.

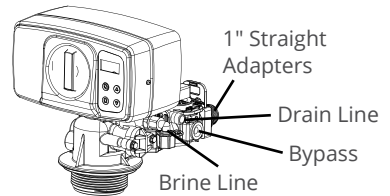
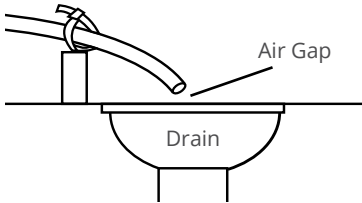

⚠ WARNING



DO NOT insert drain line directly into a drain, sewer line, or trap. Always allow an air gap between the drain line and the wastewater to prevent the possibility of sewage being back-siphoned into the softener.

7 Connect Brine Tank

1. Measure the brine tube from brine tank to brine elbow assembly on side of control valve. Cut excess tubing as needed.
2. Remove the clip on the brine elbow assembly, if included, and push the brine tube into the open port.
3. Using the included Allen key, place the system in the bypass position.

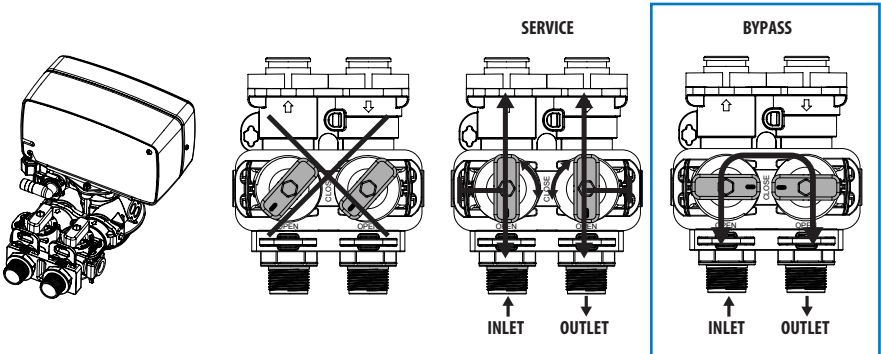

4. Slowly turn the main water supply on.
5. Turn on the nearest faucet and let water run until the water is free of any air bubbles or foreign material resulting from the installation.

8 Connect the Transformer

1. Connect the transformer to the system by plugging the 12 volt transformer into a 120 VAC 60 Hz outlet. Then, connect the power supply to the control valve power supply.
2. When the power is connected, the control screen will show the following information in sequence:

⚠ WARNING



DO NOT use an outlet that is controlled by a light switch.

Time

Remaining U.S. Gallons

9 Add Water to the Brine Tank

Open the brine tank lid and fill with water until there is approximately 1" of water above the grid plate.

NOTE: DO NOT add salt to the brine tank at this time.

10 Purge Air from the System

1. Manually turn the valve with the control knob to the backwash setting, labeled BA.WA.

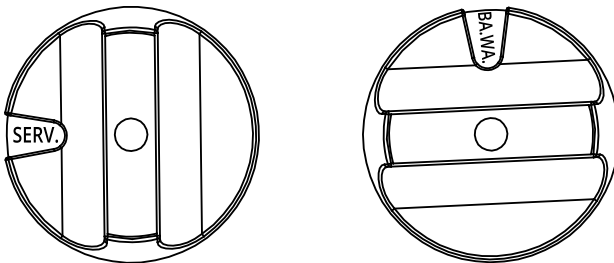

2. Open the bypass INLET slowly until there is a steady stream of water at the drain.

⚠ WARNING



Opening the bypass inlet too quickly may result in resin being expelled from the unit and into the plumbing lines.

3. With the bypass inlet now fully open, let the system run until all of the air is purged and there is a steady stream of water at the drain.

NOTE: This step may take longer than the programmed backwash cycle time, so unplug the power so that the valve will remain in the backwash position.

10 Purge Air from the System *(cont. from previous page)*

4. If the power was disconnected in step 3, reconnect the power. Manually turn the control knob to the right to the refill position, labeled REFILL. Allow the system to refill at least twice by rotating the control knob back around to REFILL until there is approximately 1" of water above the grid plate. Alternatively, water may be added manually as in Step 9.
5. Allow the control knob to return to the service position, labeled SERV.
6. Slowly open the bypass OUTLET knob until fully open.

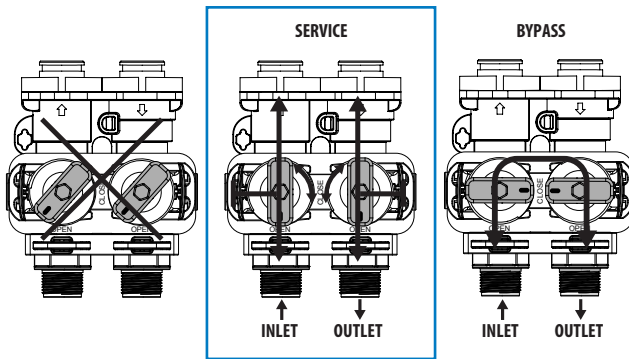

11 Program the Control Valve

NOTE: You must have your ZIP code's water hardness level (in gpg) from your city's most recent water report or have your water tested in order to program the control valve. You are required to program the time of day, the number of people living in the home, and the correct hardness setting. Iron and manganese can be found on your water report.

Compensated Hardness Calculation with Iron and Manganese Levels:

___ ppm Iron x 4 = ___ grains of hardness

___ ppm Manganese x 8 = ___ grains of hardness

Example: If Using Iron and Manganese Levels

Our water analysis states that our hardness is 15 gpg.

To this we add:

Iron = 0.5 ppm x 4 = 2.0 gpg

Manganese = 0.3 x 8 = 2.4 gpg which we round up to 3.0 gpg

We use the following hardness equation to derive our total hardness number.

Hardness = 15 gpg + 2.0 (now called compensated iron) + 3.0 (compensated Manganese) = 20 gpg

Enter 20 for total hardness when programming.





Example: If Only Using Hardness Level

Our water analysis states that our hardness is 14.55 gpg.

Enter 15 for total hardness when programming.

11 Program the Control Valve *(cont. from previous page)*

Key Pad Configuration:

- 
SETTINGS - This function is to enter the basic set up information required at the time of installation.
- 
SELECT - This function is to accept the values if changed and advance to the next page in the menu.
- 

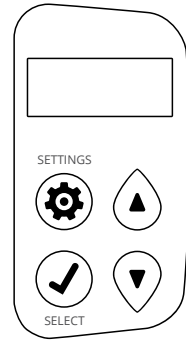
UP/DOWN - These buttons are used to increase or decrease the value of the settings while in the programming mode.



Set Time of Day

1. Press SETTINGS key to advance to TIME OF DAY. TIME OF DAY will flash.
2. Press the UP or DOWN keys to adjust the TIME OF DAY. Press and hold the UP or DOWN key to quickly advance the hour and minutes. When desired time is displayed, press SELECT.

Set Hardness

NOTE: When programming the hardness level, round up to the nearest whole number.

1. To advance to the hardness setting, press SELECT. HARDNESS will flash.
2. Press the UP or DOWN keys to adjust the hardness. When desired hardness is displayed, press SELECT.

Set Number of People

1. To advance to the people setting, press SELECT. PEOPLE will flash.
2. When desired number of people is displayed, press SELECT to complete programming.

12 Add Salt to the Brine Tank

1. Open the lid of the brine tank and add 80-100 lbs of water softener salt. Replace the brine tank lid.
2. Final installation is complete. The system will automatically fill the water to the correct level when it regenerates.

1 Manually Regenerate

To regenerate immediately, turn the center knob clockwise to BA. WA (Backwash) position. Alternatively, a regeneration can be started using the buttons on the control panel.

1. Press and hold SELECT for 3 seconds.
2. Use UP or Down arrow to select to start the regeneration the coming night (DELAY) or immediately (IMMEDIAT).
3. Confirm selection by pressing SETTINGS.

During a regeneration, you can manually advance to the next cycle by pressing the SELECT button if you want to advance without waiting for the timer for diagnostics purposes only.

2 Cleaning

1. The exterior of your system can be cleaned with warm, soapy water. Do not use any abrasive solution.
2. Rinse well with clean water.

NOTE: Never use chemical cleaning products on the system's exterior surface as they may cause damage.

3 Adding Salt to the Brine Tank

1. Check the salt level regularly.
2. Open the lid of the brine tank and add 80-100 lbs of water softener salt. Salt level must be above the brine water level.

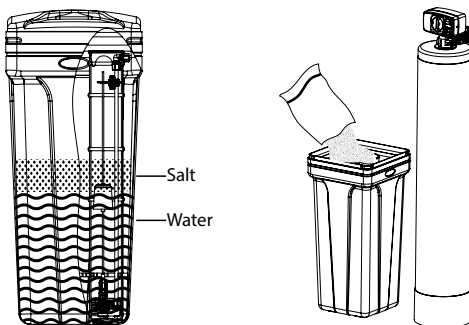

NOTE: Use only clean salt intended for water softener use, such as crystal, pellet, nugget, or button. DO NOT use natural rock salt. DO NOT mix types of salt.

4 Salt Bridging

Humidity or poor-quality salt may create a cavity between the water and the salt. This action, known as 'bridging,' prevents the brine solution from being made, and prevents your water from being conditioned. If you suspect salt bridging because of lack of soft water or salt is not being consumed, follow the below steps:

1. Use a rubber mallet to pound on the outside of the plastic brine tank or pour a small amount of warm water around the inside edges of the salt tank to break up the bridging.
2. Allow 4 hours to produce a brine solution, then manually regenerate the system.
3. Allow the system to use up any remaining salt and then thoroughly clean out the brine tank.

5 Cleaning the Brine Tank

1. Brine tanks must be cleaned every 2-3 years to remove undissolved salt sludge.
2. After cleaning, use the original start-up instructions to restart system.

6 Adding Water Softener Cleaner

NOTE: For optimal performance and to extend the life of your water softener, it is recommended to use this cleaner every 3 months.

1. Pour half the bottle (16 ounces) directly into the brine well of your system. If your softener has no brine well, pour directly into the salt tank when the salt is low.
2. Manually regenerate the softener immediately. Repeat regeneration if taste, odor, or discoloration is detected in the discharge.
3. Next, run the cold, soft water tap nearest the softener.

[Click here to purchase Aquasana Water Softener Cleaner, view cleaner instructions, and learn more.](#)

7 Service the Control Valve

Before servicing, you will need to:

1. Shut the water supply to the system off and put the softener in the BYPASS position.
2. Relieve the water pressure in the softener. Do so by turning the control into the BACKWASH momentarily.
3. Return the control to the SERVICE position.
4. Unplug the electrical cord.
5. Disconnect the drain line connection.

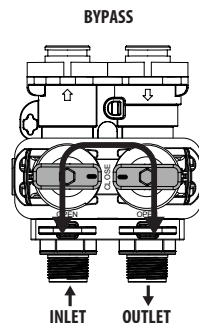

8 Clean Injector Assembly

1. After completing the above steps for servicing the control valve, reduce the water pressure by opening the nearest cold water faucet.
2. Using a screwdriver, remove the 2 screws holding the injector cover to the control valve body.
3. Carefully remove the cover and disassemble.

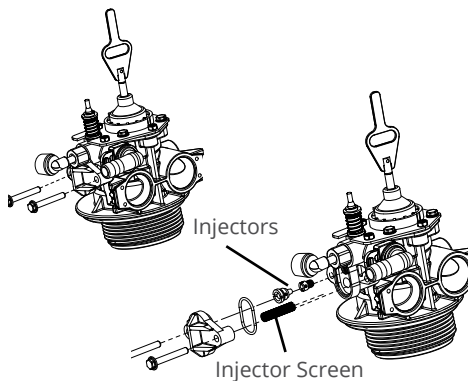

4. Using a screwdriver, carefully unscrew the injector nozzle from the valve body.
5. Using a screwdriver, carefully unscrew the injector throat.
6. Flush all parts with water, including the injector screen.
7. Use a mild acid, such as vinegar or Pro Rust Out, to clean the small holes in the nozzle and throat.
8. Reassemble by reversing the steps.

MANUAL WATER BYPASS

In case of an emergency or to perform softener maintenance, isolate your system from the main water supply using the bypass valve, located at the back of the control valve.

In normal operation, the bypass is set to OPEN with the ON/OFF knobs in line with the INLET and OUTLET pipes.

To isolate the system, rotate the knobs as indicated to the CLOSE position until they lock. You can continue to use your water, however the water will be untreated.

To resume service, OPEN the bypass valve by rotating the knobs back to the SERVICE position.

NOTE: Ensure bypass knobs are completely open. If not, untreated water may enter through the valve.

Issue	Resolution
Component is missing or arrived damaged	Call Customer Service at 866-662-6885 option 1, and then option 2, and then option 1. Please have order number, model number, and pictures of damaged packaging and/or damaged unit.
Water leak from pre/post filter housing	<ul style="list-style-type: none"> • Ensure tight connection – do not overtighten as that could cause cracks and further leaking. • Tighten the housing further with the included wrench. • If a crack is visible and/or other methods do not stop the leak, contact customer service.
System delivers untreated water	<ul style="list-style-type: none"> • Ensure the bypass valve is in the open position. • Ensure salt levels are adequate and salt is not bridged over in the brine tank. If low, refill. • Ensure the control valve is properly set for the correct hardness and number of people in the home, on page 12.
Excessive water in the brine tank	Clean the injector assembly and brine tank, on page 15.
System not regenerating automatically/not metering flow	Turn on faucet closest to system and check if gallons are counting down on valve display. If not metering, contact customer service.
System is not using salt	<ul style="list-style-type: none"> • Clean the injector assembly, on page 15. • Ensure the drain flow line is not plugged and there are no kinks or restrictions.
System not regenerating automatically, causing alarms	Unplug the power for 30 seconds, then reconnect. If alarm does not reset, contact customer service.
System is using more salt than needed	Ensure the control valve is properly set for the correct hardness and number of people in the home, on page 12.
Alarms sounding after regeneration	Unplug the power for 30 seconds, then reconnect.
Discolored water	If your area has seen water main activity, manually regenerate the system 2 times in a row to clear the color.
Excessive pressure loss	<ul style="list-style-type: none"> • Check unit specifications to ensure proper sizing for the application. • Resin may be clogged if inlet water exceeds chlorine, chloramines, or iron specifications for the water softener. Use resin cleaner and manually regenerate the system 2 times in a row to clean, then flush the resin.

Data Summary Table

	WH-SF40	WH-SF60
Max Compensated Hardness - grains/gal (mg/L)	200 grains/gal (3424 mg/L)	200 grains/gal (3424 mg/L)
Maximum Ferrous Iron Reduction - ppm	1 ppm	1 ppm
Minimum - pH	6.5 min pH	6.5 min pH
8% Cross-Linked Cation Resin - cu ft (L)	1 cu ft (28.3L)	1.5 cu ft (42.5L)
Operating Temp. Range and Ambient Temperature -°F (°C)	40-100°F (4-38°C)	40-100°F (4-38°C)
Mineral Tank Size - in. (cm)	10" I.D. x 35" (25.4 I.D. x 88.9 cm)	12" I.D. x 35" (30.48 I.D. x 88.9 cm)
Service Flow Rate - gpm	11.02 gpm	11.1 gpm
Pressure Drop at Service Flow Rate - psi	15 psi	15 psi
Maximum Flow Rate to Drain During Regeneration-Backwash - gpm (L/min)	2.4 gpm (9.1 L/min)	3.5 gpm (13.2 L/min)
Operating Pressure Range - psi (bar)	20-125 psi (1.3-8.6 bar)	20-125 psi (1.3-8.6 bar)
Minimum Water Flow Required - gpm (L/min)	2.4 gpm (9.1 L/min)	3.5 gpm (13.2 L/min)
Frequency of Regeneration	Demand	Demand
Salt Storage - lb (kg)	230 lbs (104 kg)	230 lbs (104 kg)
Height - in. (cm)	43" (109 cm)	43" (109 cm)
Footprint - in. (cm)	30" x 15" (76 cm x 38 cm)	30" x 15" (76 cm x 38 cm)
Electrical Rating	12 VAC, 60Hz, 650mA	12 VAC, 60Hz, 650mA
Plumbing Connections	1" male (MNPT)	1" male (MNPT)
Approximate Shipping Weight - lbs (kg)	92 lbs (42 kg)	120 lbs (54 kg)

This product is efficiency rated according to NSF/ANSI 44. The stated efficiencies are valid only at the specified salt dosage and flow rate.

Model	Flow Rate	Rated Efficiency	Salt Dosage	Capacity at That Dosage
WH-SF40	11.02 gpm	4,423 grains / lb	3 lbs	13,269 grains
WH-SF60	11.1 gpm	4,543 grains / lb	4.5 lbs	20,443 grains
Aquasana, Inc. 6310 Midway Road · Haltom City, Texas 76117 · 866.662.6885				

An Efficiency-rated water softener is a Demand-initiated regeneration softener that also complies with specific performance specifications intended to minimize the amount of regenerant brine and water used in its operation. Efficiency-rated water softeners shall have a rated salt efficiency of no less than 3,350 grains of total hardness exchange per pound of salt (based on NaCl equivalency) (477 grams of total hardness exchange per kilogram of salt), and shall not deliver more salt than its listed rating. Efficiency is measured by a laboratory test described in NSF/ANSI 44.

The test represents the maximum possible efficiency that the system can achieve. Operational efficiency is the actual efficiency achieved after the system has been installed. It is typically less than the efficiency due to individual application factors including water hardness, water usage, and other contaminants that reduce the softener's capacity.

Conforms to NSF/ANSI 44 for the specific performance claims below as verified and substantiated by test data.

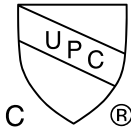

Certified by IAPMO R&T against NSF/ANSI 44 for water hardness, NSF/ANSI/CAN 372 and CSA B483.1.

- Use only clean salt intended for water softener use, such as crystal, pellet, nugget, or button. Do not use natural rock salt. Do not mix salt types.
- Softener is not intended to be used for treating water that is microbiologically unsafe or of unknown quality without adequate disinfection before or after the system.

WHO IS COVERED

AQUASANA AND ITS SUPPLIERS, (herein collectively referred to as "Manufacturer") warrants to the owner of the home where the water softener is initially installed (hereinafter "Owner"). The warranty is restricted to the water softener used in a single-family residence in the United States of America and is void if moved from the original installation location.

WHAT IS COVERED

This Warranty covers defects in materials or workmanship on the control valve (except for Wear and Tear items – Media, Piston, Seals and Brine Valve), pressure tank, and brine tank during the limited warranty period of your SimplySoft Water Softener System only as defined below. Any additional products purchased with the original system or separately (may or not include pre- or post-filters, Rhino Whole House Filters, or other products or fittings) are warranted according to the information provided in their documentation. The warranty is only valid when the water softener is installed, operated, and maintained in accordance with the instructions accompanying the product and found on Aquasana.com and not subject to freezing or vacuum. A water softener should be installed in such a manner that, if the tank or any connection thereto should leak, the resulting flow of water will not cause damage to the area in which it is installed. For detailed instructions read the manual accompanying the water softener and review drawings in the manual.

FOR HOW LONG

The warranty runs for the length of time specified in the chart below from the date of purchase by a consumer (hereinafter "Warranty Period"). No warranty coverage will be provided if the claimant is unable to provide proof of purchase. Water conditions and use rates may limit the functional lifespan of your water softener or impact the life of the aforementioned "Wear and Tear" items.

WHAT AQUASANA WILL DO

- If necessary, the Manufacturer will provide a replacement component that fulfills the remaining estimated life of your original purchase and send it to you with installation instructions. If industry standards, product improvements or product obsolescence prohibit Manufacturer from furnishing an identical model replacement water softener under this warranty, the Owner will be furnished with a new water softener of comparable capacity and functionality; however, the Owner will be charged for the additional value of the item(s) which Manufacturer has incorporated in the replacement water softener.
- Components – If a component of the control valve, the pressure tank or the brine tank proves to Manufacturer's satisfaction to be defective in material or workmanship within the warranty period listed, the Manufacturer will furnish the Owner with a replacement for the defective part(s).
- Return of Defective Water Softener and Component Parts – Manufacturer reserves the right to examine the alleged defect in the water softener or component part(s), and it will be the Owner's obligation to return the water softener and/or component part(s) to the Manufacturer at the Manufacturers request.
 - When returning a complete water softener, it must include all component parts.
 - When returning component part(s), they must be individually tagged and identified with the water softener's model number, date of purchase, and date of installation.

WHAT IS NOT COVERED

- This Warranty applies only to products purchased from authorized Aquasana resellers.
- This warranty does not cover filters cartridges, auxiliary equipment, and any systems that were not installed in compliance with the instructions or that have been abused or operated incorrectly.

- The Limited Warranty stated herein is in lieu of any and all warranties, express or implied (whether written or oral), including, but not limited to, the implied warranties of merchantability and fitness for a particular purpose.
- Manufacturer shall not be liable for any incidental, consequential, special, or contingent damages or expenses, arising, directly or indirectly, from any defect in the water softener or the use of the water softener.
- Manufacturer shall not be liable for any water damage arising, directly or indirectly, from any defect in the water softener or component part(s) or from its use.
- Manufacturer shall not be liable for any damage or product failures caused by any of the following:
 - The water softener or any of its component parts have been subject to misuse, alteration, neglect or accident.
 - The water softener has not been installed in accordance with the applicable local plumbing and/or building code(s) and/or regulations or in their absence.
 - The water softener is not installed, operated and maintained in accordance with the printed Manufacturer's instructions, including if the water softener has any additional aftermarket equipment introduced into the system not approved by the manufacturer.
 - The water softener is exposed to highly corrosive conditions.
 - The water softener is not continuously supplied with potable water.
 - The water softener is not operated within the factory calibrated temperature and pressure limits.
 - The water softener is moved from its original installation location.
 - The water softener is installed in direct sunlight or exposed to freezing temperatures.
 - The water softener or any of its component parts fail due to iron or sediment build-up or chlorine degradation.
 - Clogging due to purchaser's failure to replace the pre-filter cartridge if sold as part of the original system.
 - Damage caused by fire, flood or acts of God.
 - Damage caused by over-pressurization in the water line.
- This warranty does not cover damage caused by the use of parts that are not genuine Aquasana parts. This includes, but is not limited to replacement filters, faucets, and/or diverter valves.
- Except when specifically prohibited by the applicable state law, the Owner, and not the Manufacturer, shall be liable for and shall pay for all charges for labor or other expenses incurred in the removal, repair or replacement of the water filter or any component part(s) claimed to be defective or any expense incurred to remedy any defect in the product. Such charges may include, but are not necessarily limited to:
 - All freight, shipping, handling and delivery costs of forwarding a new water softener or replacement part(s) to the owner.
 - All costs necessary or incidental in removing the defective water softener or component part(s) and installing a new water softener or component part(s)
 - Any material required to complete, and/or permits required for, installation of a new water softener or replacement part(s), and All costs necessary or incidental in returning the water softener or component part(s) to a location designated by the manufacturer.

HOW TO GET SERVICE

To receive service under this Warranty, you must contact Aquasana (A. O. Smith Water Treatment (North America), Inc.) at 1-866-662-6885 or support@aquasana.com within the Warranty Period to describe the problem to a customer service representative who will verify that the product is under warranty and determine whether a part or the system will be replaced and whether you must send back the unit. You will be required to provide proof of purchase and proof of proper installation.

SimplySoft® Water Softener Warranty Coverage	
Component	Limited Warranty Duration
Control Valve	5 years
Pressure Vessel and Brine Tank	10 years
Installation Kit, Pre- & Post-Filter Housings <i>(if included with original purchase)</i>	12 months

This warranty does not include Rhino® Filters. See full warranty information for the Rhino® Filters in the original Rhino® manual.

This warranty does not include the UV Filter. See full warranty information for the UV Filter in the original UV manual.



Protect your investment and save money with Water for Life®.

Our Water for Life® program helps you protect the investment you've made in your family's health with an extended limited warranty on your new filtration system, a 15% discount on replacement filters, and free shipping.



Extended Limited Warranty

Our performance promise to you – free replacement parts when needed.*



Discounted Replacements

The only way to lock in a 15% discount on replacement filters.



Free Shipping

Replacements shipped to you right when you need them – at no extra cost.



No Contract

Free to join and cancel anytime – no long-term commitment required.

CONTACT US TO LEARN MORE



866-275-2319



waterforlife@aquasana.com

*Exclusions apply. Limited Warranty details are available at aquasana.com. Benefits are for the term of Water for Life membership.



LOVE IT?

Please let us know with a review on Aquasana or your retailer's website.



NEED HELP?

Give us a call at **866-662-6885** and tell us what's going on.

Aquasana, Inc.
6310 Midway Road
Haltom City, Texas 76117
866.662.6885 USA
877.332.7873 Canada
www.aquasana.com